

TITLE: POSITION DIAGNOSTICS FOR A MAGNETIC-PINCH IMPLoding-CYLINDER X-RAY GENERATOR

MASTER

AUTHOR(S): J. D. Seagrave, C. W. Woods, and L. A. Jones

SUBMITTED TO: Conference on Optics, Santa Fe, NM, April 1981

University of California

DISCLAIMER
This document contains information which is proprietary or confidential to the Los Alamos Scientific Laboratory, and is being disseminated for the use of the U.S. Government only. It is not to be distributed outside the U.S. Government without the express written consent of the Laboratory. This document is the property of the Laboratory and is loaned to you for your use only. It is not to be distributed outside the U.S. Government without the express written consent of the Laboratory.

By acceptance of this article, the publisher recognizes that the U.S. Government retains a nonexclusive, royalty free license to publish or reproduce the published form of this contribution, or to allow others to do so, for U.S. Government purposes.

The Los Alamos Scientific Laboratory requests that the publisher identify this article as work performed under the auspices of the U.S. Department of Energy



LOS ALAMOS SCIENTIFIC LABORATORY

Post Office Box 1663 Los Alamos, New Mexico 87545

An Affirmative Action/Equal Opportunity Employer



## Position Diagnostics for a Magnetic-Pinch Imploding Cylinder X-Ray Generator

J. D. Seagrave, C. W. Woods, and L. A. Jones

University of California, Los Alamos National Laboratory  
P. O. Box 1663, MS-455, Los Alamos, New Mexico 87545

### Abstract

Two diagnostic systems have been developed to assess the position and shape of a cylindrical imploding plasma sheath x-ray source. Both systems employ batteries of inexpensive nitrogen lasers. For measurement of the cylinder radius, eight 75- $\mu$ J, 1.2-ns (FWHM) nitrogen lasers provide a series of narrow beams displaced parallel to the cylinder diameter. As the plasma implodes over a 2- $\mu$ s period, these position-sampling lasers are fired in sequence at times expected to result in partial shadowing. The 2-cm wide beams strike a position-sensitive detector made up of a helical fiber-optic delay line of 2-mm pitch and 4-ns delay/turn. The clad plastic fiber is doped with Rhodamine B at the points where the 337.1-nm laser beams strike, and the fluorescent red flashes propagate along the optical delay line in both directions to avalanche photodiodes. One signal is displayed on a 5-MHz vertical raster; the other is displayed on four turns of a 2-MHz spiral sweep. The envelopes of both pulse trains are displayed on a conventional dual-beam scope. The nitrogen lasers are aligned axially and displaced radially by a system of mirrors. To assess the symmetry of the implosion, another battery of four nitrogen lasers is used to provide paraxially displaced multiple-image pinhole schlieren pictures.

### Introduction

For the diagnostic instrumentation of an imploding cylindrical plasma intended as a prototype for a high-intensity flash x-ray source, two systems have been developed which employ batteries of inexpensive 1.2-ns (FWHM) nitrogen lasers fired in sequence during the ~ 2- $\mu$ s period of the implosion. Four pinhole-schlieren paraxial photographs are taken, and eight radial profiles are obtained using a novel position-sensitive detector based on a fluorescent plastic-fiber optical delay line.

### Nitrogen Lasers

The nitrogen lasers are patterned after the lasers built by E. Bergmann;<sup>1</sup> they work on the principle of amplified spontaneous emission with no optical cavity. The lasers consist of two aluminum electrodes of 1/2" thickness and 8" length with variable separation resting on a 1/16" thick double-sided printed circuit (PC) board. The upper half of the PC board is stripped of copper between the electrodes and a 1 megohm resistor is used to tie the electrodes together. The bottom of the board is left intact and grounded while the upper half of the board is charged to 10 - 15 kV. Nitrogen is introduced between the electrodes and allowed to escape at atmospheric pressure from the end of the channel formed by the electrodes, the PC board and a dielectric cover. Nitrogen flow is approximately 2 scfh. To fire the lasers a triggered spark gap is used to switch the upper part of the printed circuit board to the lower, grounded part at an extreme end of the board. The PC board then acts as a Blumlein circuit and an EM wave is launched from the spark gap toward the electrodes. When this wave reaches the near electrode it is reflected by the high impedance between the electrodes and twice the charge voltage appears across the electrodes; this triggers a short-lived discharge between the electrodes. Electrode gap, spacing and wedge angle must be set appropriately to get a clean blue-white discharge. If no optics are used, light is emitted from both ends of the electrode gap. For increased energy output, with slight degradation in the pulse width, a mirror may be added at one end of the gap. Addition of a properly aligned mirror also dramatically reduces the divergence. The energy output of the lasers we have built is approximately 30  $\mu$ J at each end, without the mirror, and 75  $\mu$ J with the mirror; gain on the second pass is thus observed. A cylindrical mirror ( $r = 70$  cm) was used on the eight-laser system to produce the desired 2-cm length at 2 m from the laser.

### Radial Position Sampling

#### Hardware

The basic scheme for radial position sampling is illustrated in Figure 1. The initial diameter of the aluminized plastic foil which forms the plasma is 14 cm. When a high-current pulse vaporizes it, a magnetic-pinch implosion is initiated. This choice is based on prior work<sup>2</sup> at the Air Force Weapons Laboratory (AFWL) at Kirtland Air Force Base in

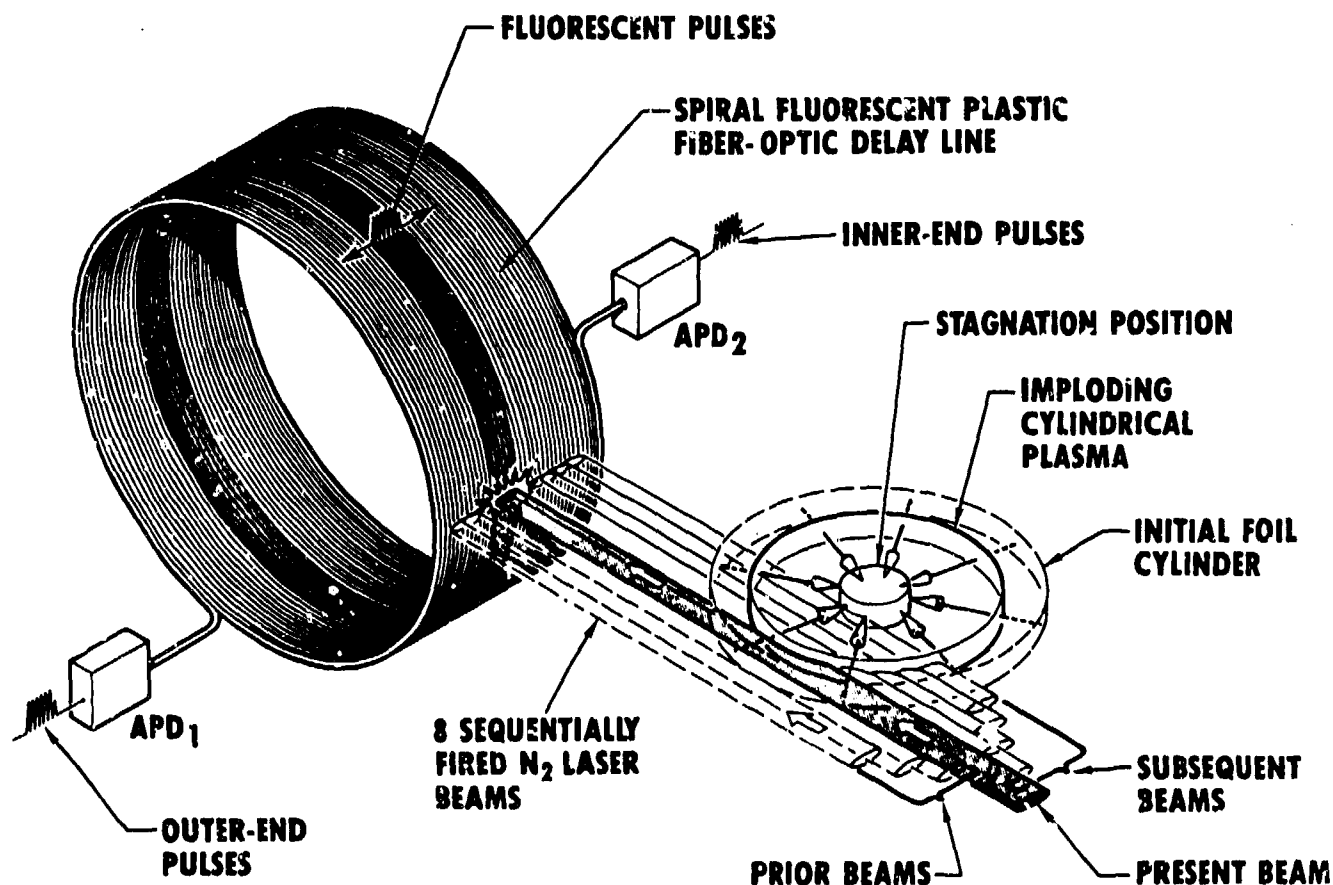

Figure 1. Simplified sketch of the position-sensitive radial shadowmeter. Eight broad nitrogen laser beams are displaced parallel to a diameter of the initial foil, and are fired in sequence as the foil implodes. The portions of the beams which are not obscured by the plasma strike multiple turns of a plastic fiber spiral delay line. Fluorescent light bursts originating at the points struck travel in both directions down the fiber to avalanche photodiodes.

Albuquerque, NM. Eight nitrogen laser beams are constrained to diverge to about 2 cm in the radial direction, and are focused by a quartz cylindrical lens to about 3 mm in the axial direction at the position of the detector. These eight beams overlap in space, with their centers displaced by 1 cm over a radial span (at the plasma) of about 8 cm. After initiation of the discharge, the lasers are fired in sequence at times indicated by previous experience so that the beams are partially intercepted by the moving plasma boundary.

The position-sensitive detector consists of a spiral of PIFAX<sup>3</sup> PIR-140 clad plastic-fiber optical cable stripped at the points of laser incidence, and coated with a fluorescent red lacquer containing a soft acrylic binder in a solvent mixture developed in connection with Gary E. Mueller.<sup>4</sup> This formulation avoided excessive attenuation from light leakage due to solvent attack on the fluorocarbon cladding and the acrylic fiber core. Initial studies used Rhodamine B (practical) dye, but better results were later obtained with Laser-grade dyes<sup>5</sup> Rhodamine 610, Rhodamine 640, and LD-700. The best results maximized the product of a) fluorescent conversion of 337.1-nm UV light from the laser to 600 - 700-nm light from the dye, b) coupling efficiency into the fiber core for the red light, c) transmission of the red light through the fiber delay line, and d) the spectral response of the silicon diode. This technique was developed after observing that CROFON<sup>3</sup> fiber fluoresced at 480 ± 50 nm. The attenuation in that fiber is excessive for our present application.

The 0.4-mm bare fibers are supported at ~ 2-mm spacing by aluminized brass 1/2"-13 screws which also support ~ 2-mm diameter quartz rods which focus the incident UV light on the fibers. Forty turns provide position sensing with 2-mm resolution over the 8-cm span of the laser beams. The ~ 2-cm swath of each laser beam thus generates a train of up to ten optical pulses in the red dye emission band. These propagate in both directions to avalanche photodiodes which convert the optical pulses to electrical pulses.

The optical pulses exhibit the 0.5-ns rise of the laser pulses, but decay with about a 10-ns time constant. After electrical conversion in the avalanche photodiodes, the signals are clipped to a width of 2 ns at the 10 percent level by a combination of broad-band 180° splitters and combiners with about a 1-ns delay in the opposite-polarity line. Because of broadening due to dispersion in the fiber, the delay per turn was chosen to be 4 ns to insure adequate resolution at the far ends. For a total delay of 160 ns with a nominal core index of  $n = 1.49$ , this resulted in an active length of  $\sim 33$  m and a full-length attenuation factor of 0.2. An interference filter of bandwidth 4 nm and attenuation of 0.25 is placed in front of the detector spiral to discriminate against the expected blackbody radiation from the  $\sim 5$ -eV plasma. A 3-mm slit corresponding to the focused beam provides additional spatial discrimination.

### B. Display

Three methods of display are being employed as indicated schematically in Figure 2.

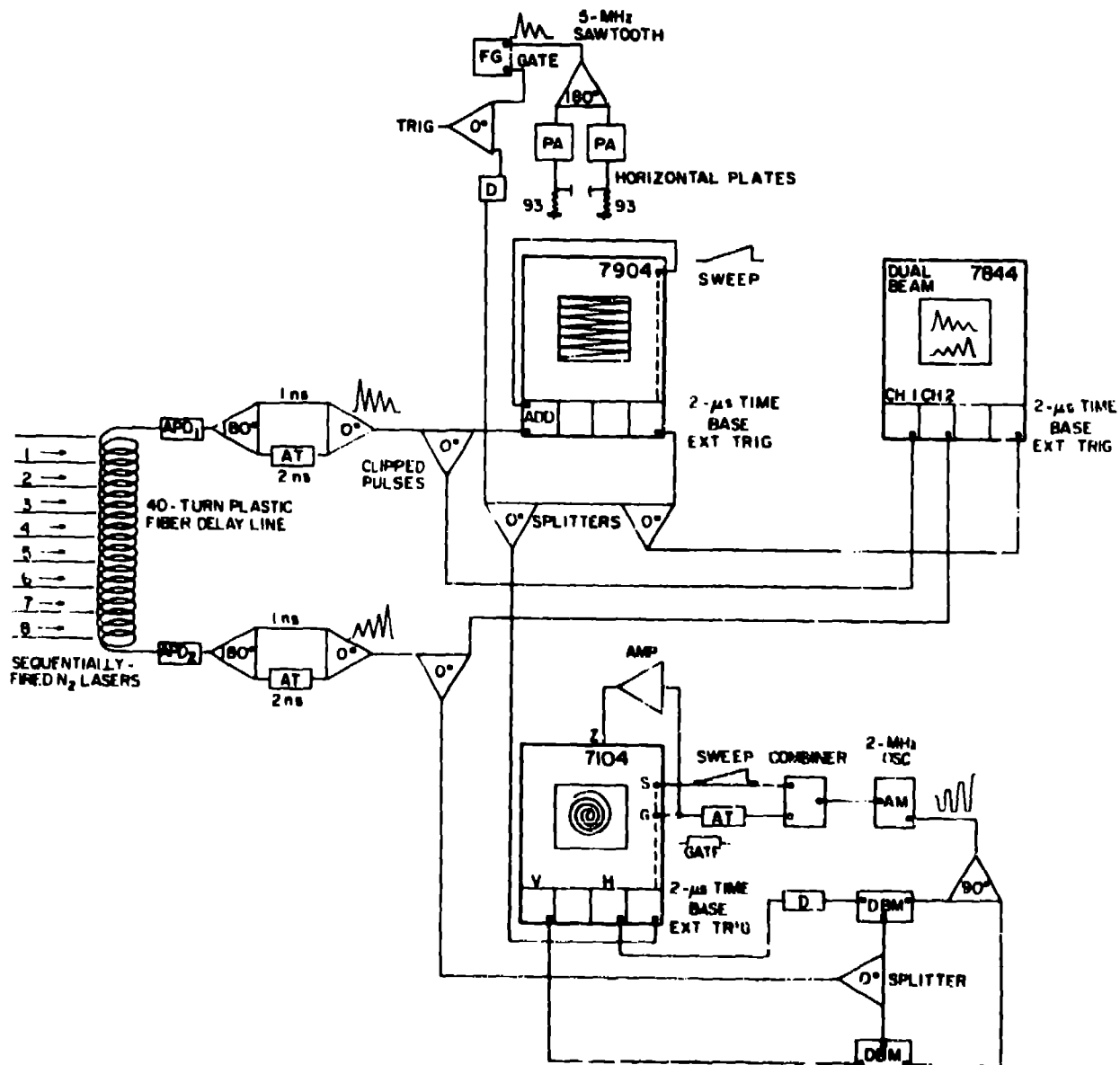

Figure 2. Electrical schematic of pulse conditioning and display of signals from fluorescence of a plastic fiber delay line excited by 337.1 nm light from nitrogen lasers. Key: APD - avalanche photo diode; AT - 50-ohm attenuator; D - delay; FG - function generator; PA - power amplifier; DBM - double-balanced mixer.

A 5-MHz zig-zag vertical raster is obtained by gating a 5-MHz triangular function generator for a 2- $\mu$ s period while mixing a 2- $\mu$ s ramp with the data signals from the outer end of the delay line for display on the vertical axis of a Tektronix 7904 oscilloscope; the horizontal plates are driven in push-pull by a pair of 3-W 300-MHz power amplifiers. The signal from the other end of the delay line is displayed on four turns of a 2-MHz spiral sweep using a Tektronix 7109 oscilloscope in x-y mode. The "idle" horizontal timebase unit is triggered to provide 2- $\mu$ s ramp and gate signals which are combined to modulate a 2-MHz oscillator. This signal is applied to a 90° splitter<sup>6</sup> and the two outputs are applied to a pair of double-balanced mixers<sup>6</sup> whose control ports are presented with identical splittings of the data signal. This results in a spiral sweep, radially modulated by the signal. Finally, splittings of both signals are sent to a conventional Tektronix 7844 dual-beam oscilloscope which displays the envelopes of the two signal trains. This redundant three-way system is employed because the available trigger signal is uncertain in absolute time by  $\pm 50$  ns. The more accurate linear raster risks wrap-around confusion at the vertices; the spiral sweep is nonlinear and less accurate, but is insensitive to trigger timing. The dual-beam display cannot follow the fine-structure of the pulse trains, but is free of distortion due to the trigger uncertainty.

Figure 3 offers a sketch of the raster display of the signal from the outer end of the delay line, while Figure 4 offers a sketch of the spiral display of the corresponding signal from the inner end of the delay line. The sketches indicate the same hypothetical case, including the effect of attenuation and the number of clear and partially-obscured pulses.

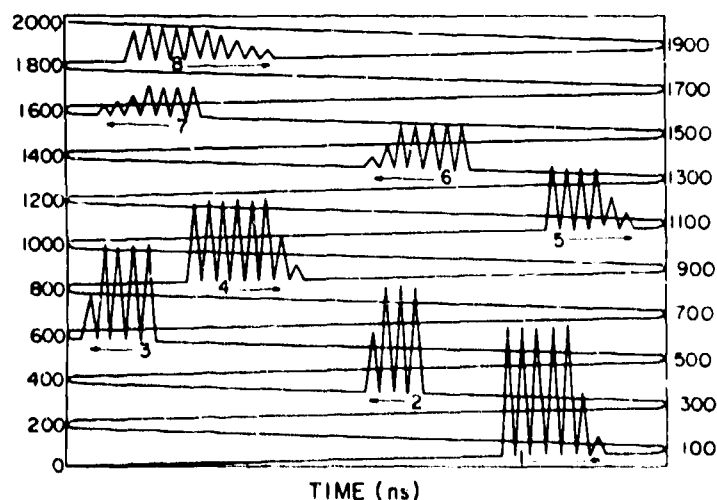

Figure 3. Sketch of signals from the outer end of the position-sensitive spiral detector, displayed on a 5 MHz vertical raster.

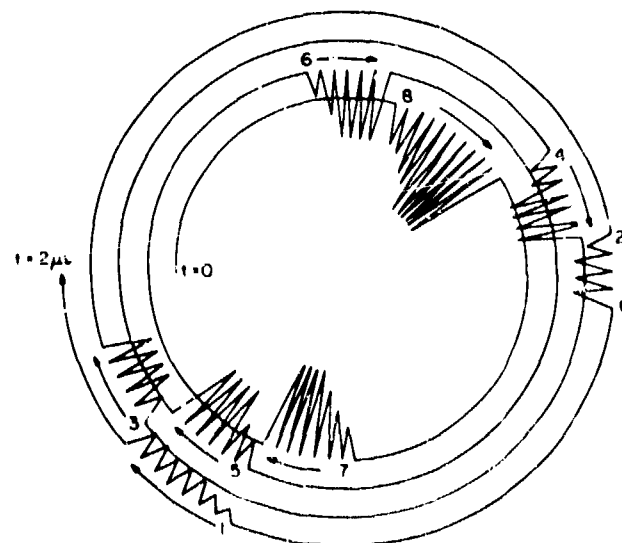

Figure 4. Sketch of signals from the inner end of the position-sensitive spiral detector, displayed radially on a 2 MHz spiral sweep.

#### IV. Paraxial Schlieren Photography

The transverse shadowgraphic technique described above provides information about the radial position of the outside of the plasma as a function of time along a selected radius. To assess the symmetry of the implosion, paraxial pinhole-schlieren photographs are taken of the inside boundary of the plasma at four times independent of the radial probe times.

A schematic of the schlieren scheme is shown in Figure 5. The four pictures are angularly multiplexed onto a single piece of film using a four-pinhole array and one lens. The distances  $L_1$  and  $L_2$  are chosen so that the plasma is imaged onto the film plane. This gives a sharp shadowgraph. The laser light is focused at the pinhole, while the plasma light is not -- giving some discrimination of the laser light over the plasma light. In order to separate the images of the four beams a low magnification of 1/5 is used. This still gives a resolution at the plasma of better than one millimeter.

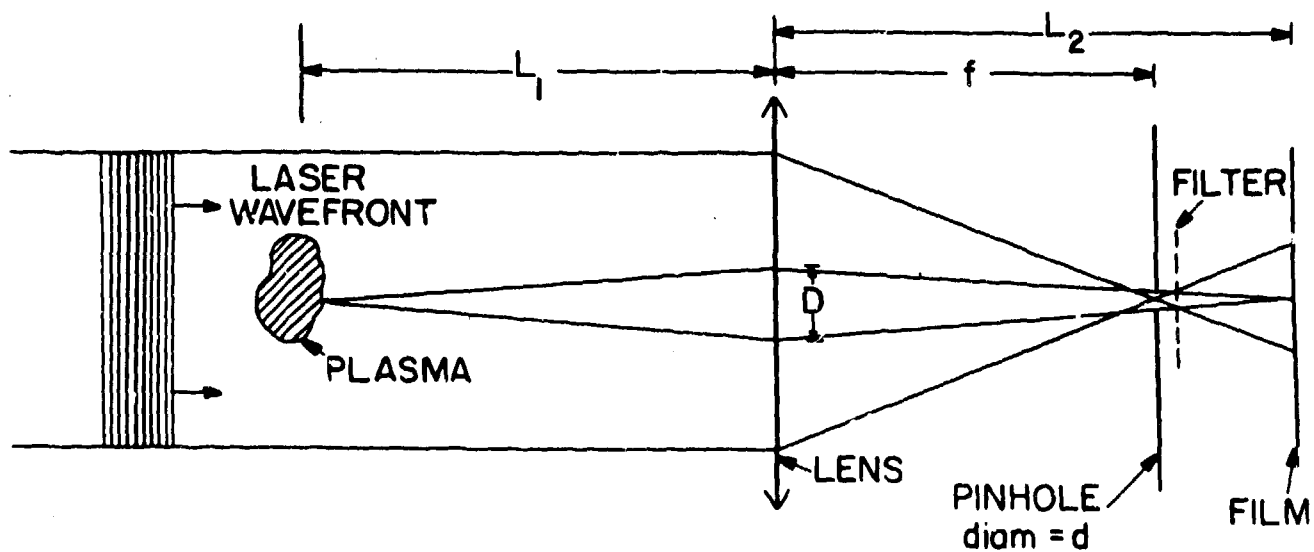

Figure 5. Elementary optical diagram of components for schlieren shadowgraphy.

#### Acknowledgment

The research work leading to this paper was performed under the auspices of the US DOE, Contract No. W-7405-ENG-36.

#### References

1. Based on t. Bergmann, Rev. Sci Inst. 48, 545 (1977) and private communication 1980.
2. W. L. Baker, M. C. Clark, J. H. Degnan, G. F. Kiuttu, C. R. McClenahan, and R. E. Reinovsky, J. Appl Phys. 49(9), 4694 (1978).
3. Dupont Trademark
4. G. E. Mueller, Solarchromic, Inc., 2103 Essex Lane, Colorado Springs, CO, 80909.
5. Exciton Chemical Co., Inc., Box 3204, Overlook Stn., Dayton, OH 45431, and R. Steppel, private communication.
6. Broad-bandwidth splitter-combiner units were obtained from Mini-Circuits, 2025 E. 14th St., Brooklyn, N.Y. 11235.